

# Investigations on Combined Operation of Industrial Distribution System and utility in Distributed Generation Environment

K. Manjunatha Sharma, K.P. Vittal, *Member, IEEE*, and T.K. Nagaraja Rao

**Abstract**— The deregulation regime has given lot of scope for independent power producers to feed power to the utility nearest to the load center. This feature provides opportunities for lot of improvements in distribution system operation. In this paper investigations have been done for integrated operation of the practical MRPL industrial distribution plant having its own captive generation to act as distributed generation source serving neighboring utility loads. The performance of the system is simulated in both cases of industry acting as source and sink depending on the load cycle. The simulation results will serve as useful tool for decision making in power trading during ABT regime.

**Index Terms**— ABT regime, Distributed Generation, Independent Power Producers, Power Flow Studies, Power Trading, Voltage Profile.

## I. INTRODUCTION

THE power distribution networks have recently acquired enormous importance in order to achieve efficient operation of electrical system. Distribution Automation (DA) is a promising tool to address the problems associated with the operation and control of the networks.. Because of the complexity of the network, their simulation studies is always a challenging field of research. Recently developments in distribution automation have brought the opportunity to offer higher quality service by means of the implementation of new operation functions. Many applications, such as network optimisation, reactive-power planning, feeder reconfiguration, state estimation, short-circuit analysis are incorporated in the

design of distribution automation scheme effectively. While carrying out analysis based on simulation of distribution networks, building the appropriate model is very much essential to obtain results matching with the field values. The industrial distribution system having its own captive power generation need to focus on the power generated by the generators and the power consumed by the load during varying load cycle and to achieve optimum system losses. This aspect necessitates the modeling of the entire distribution system and performing power flow analysis at various typical instants in order to arrive at network operation and control strategies.

The load flow calculation for electrical systems is one of the most vital aspect and forms the knowledge base for the energy management in the system.. Its accuracy is crucial to power system security and stable operation. The possible errors during the power flow may be due to the following factors :

- The mathematical model of each component (such as: transformers, distribution feeders) is not consistent with the actual situation.
- The parameters of each component is not consistent with the actual situation.

Mathematically the load flow requires a solution of a system of simultaneous nonlinear equation.

The radial distribution system power flow has also received large amount of work by researchers. The aim is at arriving at faster convergence, making the technique suitable for on-line applications. The system data poses severe constraints on the computations. The forward backward substitution method has been accepted and widely used because of simplicity and less computation time [1].

The distribution system need to be monitored carefully for efficient and safe operation. This aspect is much essential in industrial plant where continuity and quality of supply need to be ensured. The control strategies to be used in industrial distribution system are governed by the load forecasting, power flow analysis, network reconfiguration and protection methodologies. The simulation of the industrial distribution network under various operating conditions help the decision making process and appropriate control action can be commanded for system improvement [4].

---

This work was supported by Ministry of Human Resource and Development under Research and Development Scheme.

K. Manjunatha Sharma is with the Department of Electrical and Electronics Engineering, National Institute of Technology Karnataka, Surathkal – 575025, India (e-mail: manjusuma@yahoo.com)

Dr. K.P. Vittal is Assistant Professor in the Department of Electrical and Electronics Engineering, National Institute of Technology Karnataka, Surathkal – 575025, India (e-mail: vital\_nitk@yahoo.com)

T.K. Nagaraja Rao is working as plant engineer at MRPL, Mangalore and PG scholar in the Department of Electrical and Electronics Engineering, National Institute of Technology Karnataka, Surathkal – 575025, India (e-mail: tknagaraj@rediffmail.com)

0-7803-9772-X/06/\$20.00 ©2006 IEEE

The reforms in the distribution sector has been launched globally by deregulation policy. In India, Electricity Act 2003 [7] which has come into force from 2003 aims at restructuring of the distribution system. The act provides for establishment of competitive distribution companies, independent power producers, strict guidelines for power quality. Since the establishment of this act regular amendments are being done, and the nation is moving towards implementation of the act. The Government of India is taking all possible measures to improve the performance of the distribution system to stay tuned with global trends. Since past two years the act has resulted in better service, good governance from electricity regulatory commissions and more benefits are expected in forthcoming years.

The deregulation policy emphasizes on Distributed Generation or Co-generation where in generators are hooked on to the distribution network to improve the system performance. As accepted at international level since 2003, distributed generation has brought dawn of a new era [2] [3]. The technical benefits of distributed generation are reduced line losses, voltage profile improvement, increased overall energy efficiency, enhancement of system reliability and security, improved power quality, relived T & D congestion. The economic benefits are deferred investments for upgrades or facilities, reduced O & M costs of DG technologies, increased security for critical loads, peak load shaving.

The power trading depending on the load cycle can be done efficiently with this simulation tool [5][6], which is a quite important aspect in ABT regime. This paper presents the simulation studies on Industrial Distribution System which comprises of its own captive generation and industrial load and this installation is serving as distribution generation source feeding the neighboring utility. The simulation results validate the feasibility of the integrated operation and the effective operation of both the industry and utility owing to diversified load cycles.

## II. SKM POWER TOOLS PACKAGE

The Load Flow Study conducted on SKM Power Tools Package [8], predicts the overall apparent real and reactive power distribution throughout a power system, including associated losses. Additionally, the study calculates the voltage drop through each branch impedance component, and the associated voltages at each bus or node in the electrical system.

The solution depends on the system topology, combined with knowledge of associated branch impedances and load data. The formation of the appropriate matrices and, through optimal ordering and standard matrix algebra techniques, solves for the dependent variables. The power flow solution technique used is the double current injection method. In this method, the first estimate assumes no losses and calculates the current flows in each branch, given the load values and system nominal voltages. Subsequently the system losses are calculated, the voltage drop is determined for branch and bus.

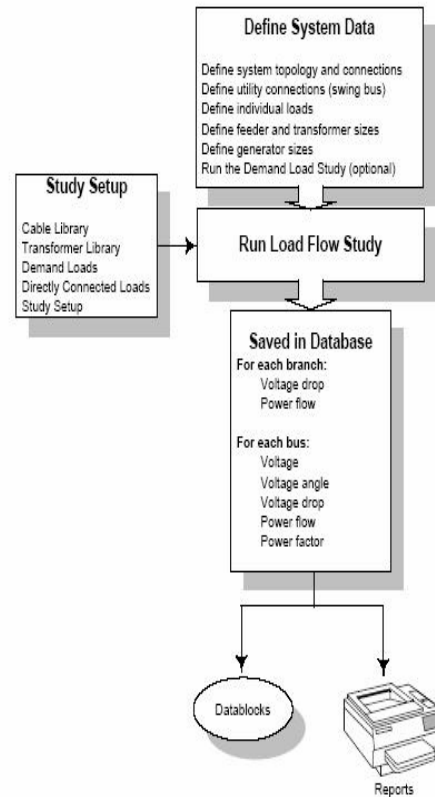

Fig. 1. Flow chart with features pertaining to load flow studies.

Given this new voltage at each bus, the load currents are recalculated, and the iterative process begins. The new currents develop new losses in the branches and thus new voltage drops in each branch and bus. The iterative process continues until there is little change in the voltage at each bus between estimates, and convergence is achieved. Transformer primary and secondary tap settings and transformer off-nominal voltages are considered in the steady-state load flow solution. These transformer settings are to be dynamically controlled through automation scheme to obtain optimum operation of the system.

The load flow solution takes into account load characteristics to calculate the apparent load flow conditions in the distribution system. The load flow conditions are solved in harmony with solution of the voltage conditions at each load bus. The type of loads are specified and the system losses significantly influence the results of the load flow and voltage drop calculations. The modeling of the load points are crucial in deciding the condition of the network. Hence it is necessary to account for different characteristics of loads present in the plant. The load cycle variations also poses a challenge in the network operation owing to different pattern of loads coming over. Hence the strategies of network operation need to be decided on the load demand level as well as characteristics of the load at any typical instants.

The total voltage drop in any one branch or the total bus voltage drop is calculated as per NEC standards, USA. Thus, it is critical to know the voltage drop in each branch of the power system, and the total voltage drop from the source of supply to the bus in the branch circuit. The voltage drop calculations are incorporated directly into the calculation of the steady-state load flows. Before carrying out the load flow study it is required to fulfill the following requirements :

- Topology, and connections are to be defined
- Utility connection (swing bus) is to be defined
- Individual loads to be defined
- Feeder and transformer sizes are to be defined
- Generator sizes are to be defined

### III. SHORT CIRCUIT STUDIES

The short circuit study models the current that flows in the power system under abnormal conditions and determines the prospective fault currents in an electrical power system. These currents must be calculated in order to adequately specify the ratings of the protection apparatus. The study results are also used to selectively coordinate time current characteristics of electrical protective devices.

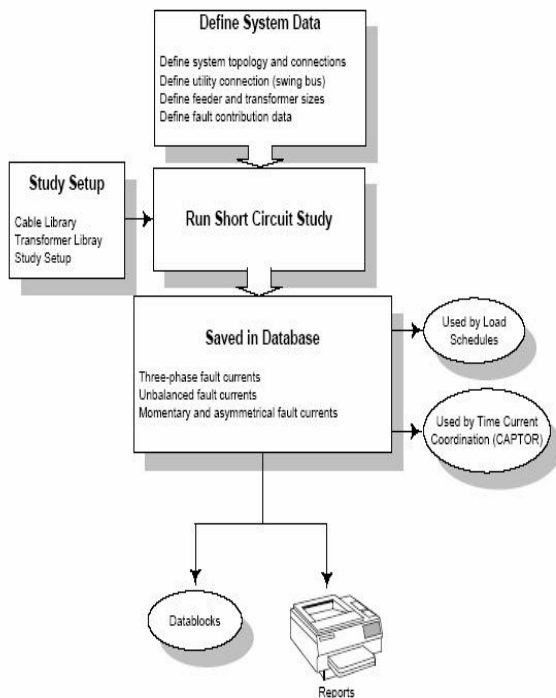

Fig. 2. Flow chart with features pertaining to short circuit studies.

The short circuit study requires all the data pertaining to the power flow studies, in addition the fault contribution data need to be specified. The model developed will be useful for

various types of fault analysis in the distribution system. During short circuit study run, check is done for appropriate feeder sizes and lengths, and transformer sizes in the library. If the data is inappropriate or missing, error and warning messages are shown in the study Run dialog box which are included in the report. The positive-sequence impedance of the cable and one-way circuit length is specified. The modeling is done treating negative-sequence impedance as equal to the positive-sequence impedance. If a cable's zero-sequence impedance is zero, the short circuit study uses the positive-sequence value. Cable positive and zero sequence impedances may be selected from the cable library, or can be defined them in the component editor.

If the cable user defined, then specific cable impedance in ohms per 1000 feet or ohms per 1000 meters need to be specified. Cable lengths must be entered in the same units as the cable impedance data (feet or meters). Cable impedances are unaffected by the wire circuit description characteristics.

### IV. MOTOR TRANSIENT ANALYSIS

The flow chart provides a quick overview of the necessary steps in motor transient analysis.

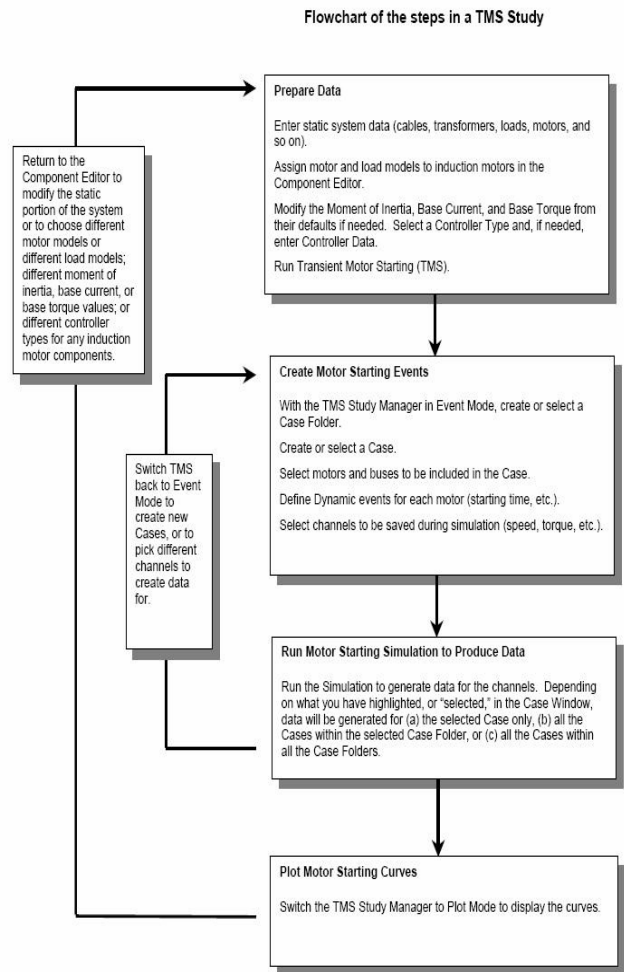

Fig. 3. Flow chart with features pertaining to motor starting studies.

- Data Preparation: system data - cables, transformers, all types of loads and devices.
- assigning dynamic motor and load models of induction motors in the component editor; and running Transient Motor Starting engine
- Creating cases: This include, with TMS in Event Mode, creating or selecting a Case; selecting motors and buses for including in the dynamic Case events. Defining Dynamic events for each motor (starting time, etc.). Selecting motor data for saving during simulation (speed, torque, etc.).
- Running TMS study engine to produce data : This includes running the Study engine to generate data for the channels. Depending on requirement “selected,” data will be generated for (a) the selected case only, (b) all the cases within the selected case folder, or (c) all the cases within all the case folders.
- Plotting motor starting curves : This was included for switching TMS to plot mode to display the plot curves. (For creating new cases, or to pick different channels to create data for, return to step of creating cases. To choose different motor models, different load models, different moment of inertia values, or different controller types for any induction motor components, return to data preparation step.)

## V. CASE STUDIES AND RESULTS

The electrical power distribution system of Mangalore Refineries and Petrochemicals Ltd. (MRPL) is simulated using SKM power tools. The system comprises of the generators, transformers, switchgears, cables, motor loads. The plant layout has been categorised as Phase – I , Phase – II. These Phase – I and II can operate independently and also in integrated manner. The industry can either import power from the utility or export power to it. Considering these probabilities the case studies have been formulated as below.

- Case Study 1 : Phase – I Generators and Load Exists
- Case Study 2 : Phase – II Generators and Load Exists
- Case Study 3 : Both Phase – I and Phase – II Generators and Load Exists, Integrated Operation of Phase – I and Phase – II.
- Case Study 4 : Integrated Operation of Phase – I and Phase – II with Power Import from the Utility Grid
- Case Study 5 : Integrated Operation of Phase – I and Phase – II with Power Export to the Utility Grid

In each of the above cases, the parameters of the plant are tuned to meet the power flow constraints. The simulation results obtained are matching with the field results for the normal configuration considered as case study 3. The voltage profile is found conforming to the industrial standards. The lay out of the MRPL industrial system and power flow results obtained are presented in the following section.

### Case Study 1 :

Generation - STG 1 : 7.69 MW, STG 2 :13.00 MW  
Plant load demand : 20.57 MW,  
System losses : 0.12 MW.

### Case Study 2 :

Generation - STG 3: 6.73 MW, STG 4 :5.20 MW,  
STG 5 : 5.20 MW,  
Plant load demand : 16.90 MW,  
System losses : 0.23 MW.

### Case Study 3 :

Generation – STG 1 : 14.00 MW, STG 2 : 12.68 MW,  
STG 3 : 9.01 MW, STG 4 : 0 MW,  
STG 5 : 14.0 MW,  
Plant load demand : 49.27 MW,  
System losses : 0.42 MW.

### Case Study 4 :

Generation – STG 1 : 15.57 MW, STG 2 : 0 MW,  
STG 3 : 9.01 MW, STG 4 : 0 MW,  
STG 5 : 14.00 MW,  
Import from Utility : 11.30 MW,  
Plant load demand : 49.27 MW,  
System losses : 0..60 MW.

### Case Study 5 :

Generation – STG 1 : 24.16 MW, STG 2 : 0 MW,  
STG 3 : 13.00 MW, STG 4 : 0 MW,  
STG 5 : 15.00 MW,  
Export to Utility :.2.28 MW,  
Plant load demand : 49.27 MW,  
System losses : 0..60 MW.

In all the configurations, the network control is done so as to maintain good voltage profile and ensuring scope to handle contingent conditions arising in the industrial plant.

Short circuit analysis indicated that the protection system is capable of handling the fault conditions both under independent operation of the plant and combined operation of the plant and utility.

The schematics of the Phase I and II of MRPL electrical power distribution system is shown in Fig. 4 and Fig. 5.

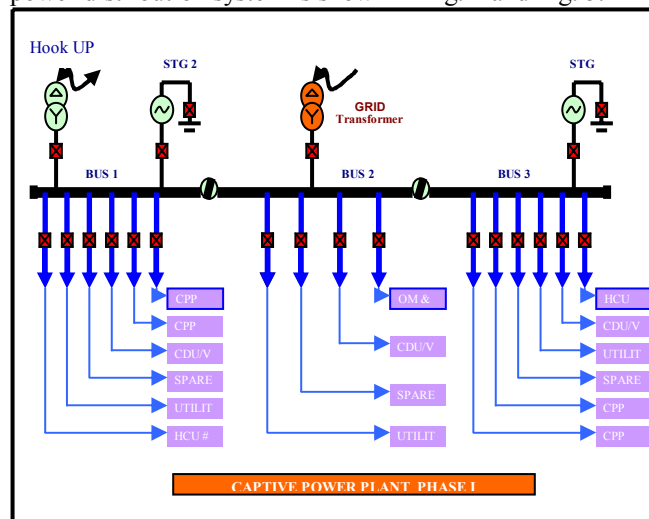

Fig. 4. MRPL industrial power distribution system – lay out of phase – I.

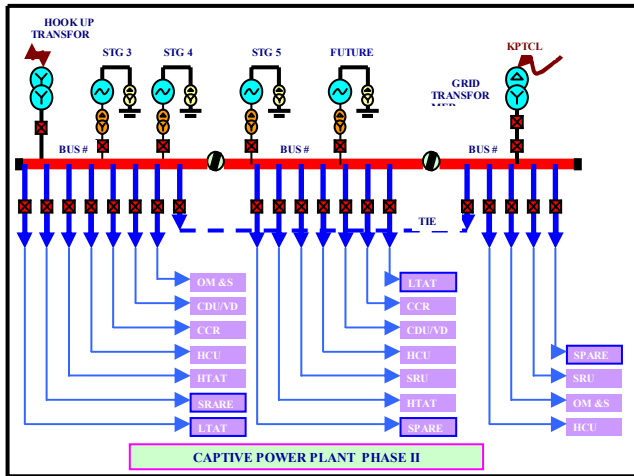

Fig. 5. MRPL industrial power distribution system – lay out of phase – II.

Motor starting analysis indicated that the parameters of the network are well within limits with the combined operation of the plant and utility and varying load cycle can be handled effectively with network control strategies. It is planned to extend the analysis for techno-economic feasibility studies.

#### VI. ACKNOWLEDGEMENT

The authors acknowledge the support extended by MRPL and NITK, Surathkal authorities for carrying out this work.

#### VII. CONCLUSIONS

In this paper, simulation studies have been carried out for performance analysis of Industrial Plant serving the neighboring utility, acting like distributed generation source. In ABT regime, power trading is a vital factor for determination of the plant operation and efficiency. The simulation results have shown the feasibility of such operation. The detailed analysis for exploring the economics of the combined operation of the plant and the utility is proposed in future.

#### VIII. REFERENCES

- [1] D. Thukaram, H.M. Wijekoon Banda, Jovitha Jerome, "A Robust power flow algorithm for distribution systems," *Electrical power system research*, vol 50, pp. 227-236, 1999.
- [2] Hans B Puttgen, Paul R Macgregor, Frank C Lambert, "Distributed Generation : Semantic Hype or the Dawn of a new era? ", *IEEE Power and Energy Magazine*, pp 22-29, Feb. 2003
- [3] Roger Dettmer, "Empowering Distributed Generation", *IEEE Review*, pp51-53, Jan. 2003
- [4] Terence hazel Isabelle Condamine, Fabrice Audemard "Facilitating Plant operation and maintenance using an electrical network monitoring and control system simulation tool", in *Proc. 2004 IEEE Petroleum and Chemical Industry Technical Conf.*, pp 361 – 369.
- [5] Hugo Morais, Marilo Cardoso, "A Decision Support Simulation Tool for Virtual Power Producers," presented at IEEE Int. Conf. on future Power Systems, Netherlands, 2005
- [6] G Strbac, J Mutale, D Pudjianto, "Pricing of Distribution Networks with Distributed Generation," presented at IEEE Int. Conf. on future Power Systems, Netherlands, 2005
- [7] Ministry of Power, Government of India, "Electricity Act 2003.",
- [8] SKM System Analysis Inc., USA, "SKM Power Tool for Windows".